

CARMIX CARSILOS

CARMIX
Italian family factory

**EFFICIENT CEMENT SILOS
TO OPTIMIZE YOUR JOBSITE**

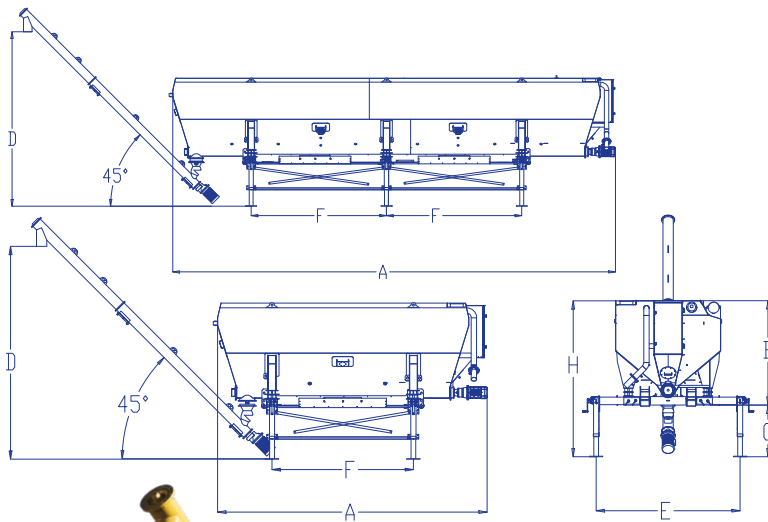

	CARSILOS HC 16	CARSILOS HC 26	CARSILOS HC 36
A	5840	8976	11540
B		2230	
C		2230	
D		4485	
E		3400	
F	3000	4400	3500
G		1220	
H		2920	

All sizes are quoted in mm.



ACCESSORIES ON DEMAND

Kit CE

Water plant with 2 water tanks (L 1.260 each), pump and water meter

Wireless remote control start/stop screws conveyor

Electrical customization

CARMIX CARSILOS



Electronic weighing system with load cells complete with digital instruments and automatic measuring management.



Complete with fluidification system, vibrators and discharging screw conveyor.



Main frame complete with 4/6 telescopic stabilizers for loading and unloading operations from the truck. No need of other lifting equipment.



Electric control panel complete with additional emergency devices.



Static filter for dust recovery with hopper.



Designed to fit 40" box high cube.

CARSILOS HC 16

(16 M³)

TOTAL STORAGE CAPABILITY	16 m ³
THEORYC PRODUCTION	480 kg/l
EMPTY PLANT WEIGHT	4100 kg
ABSORBED POWER	13 kW
THREE-PHASE TENSION FEEDING	400 V, 50 Hz

CARSILOS HC 26

(26 M³)

TOTAL STORAGE CAPABILITY	26 m ³
THEORYC PRODUCTION	480 kg/l
EMPTY PLANT WEIGHT	6200 kg
ABSORBED POWER	13 kW
THREE-PHASE TENSION FEEDING	400 V, 50 Hz

CARSILOS HC 36

(36 M³)

TOTAL STORAGE CAPABILITY	36 m ³
THEORYC PRODUCTION	480 kg/l
EMPTY PLANT WEIGHT	7050 kg
ABSORBED POWER	15 kW
THREE-PHASE TENSION FEEDING	400 V, 50 Hz

CARMIX
EVERYWHERE
YOU BUILD