

CARMIX 25FX

CARMIX
Italian family factory

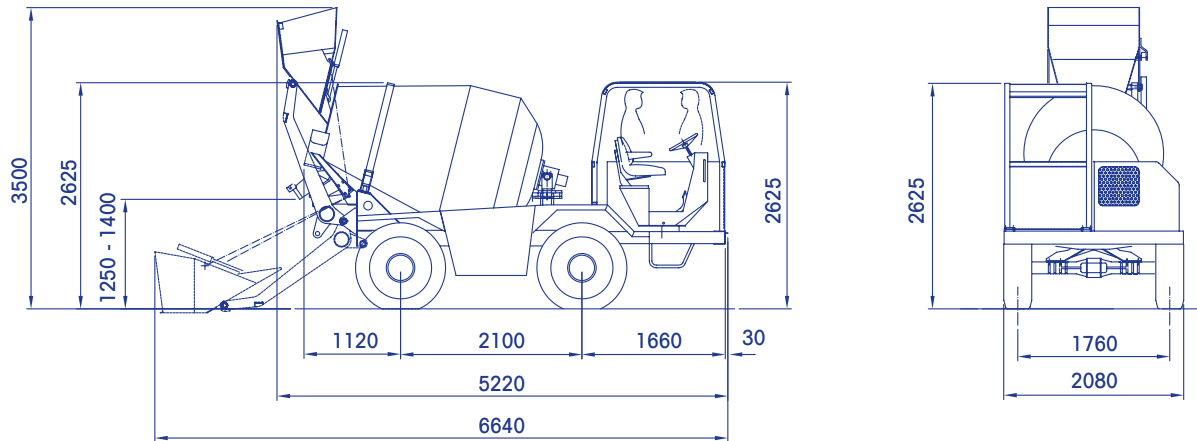

ACCESSORIES ON DEMAND

High-pressure washing pump (90 BAR) with gun

Spare wheel

Additional discharging chute (100 cm)

Front camera

Weighing system Millennium

CARMIX 25FX



MIXING UNIT

Drum capacity 3.450 liters. Concrete output: 2,5 m³ per batch. EN 206-1 SLUMP S1 class, yield no vibrated. Double mixing screws, cover for emergency unloading. Mixing and discharging speed independent from r.p.m. of diesel engine. Discharging by reversing drum.



ENGINE

Perkins 1104D-44T Turbo-Diesel Tier 3, water-cooled, 4 cylinders Tier 3. Power KW 62,5 (84 HP) set at 2200 rpm.



TRANSMISSION

Hydrostatic Bosch-Rexroth. Heavy duty differential axles with planetary reducers. Front axle swinging and steering. Rear axle steering.



AXLES

Comer with oil bath disc brakes and planetary reducers.



SPEED

Working speed from 0 to 10 km/h, road transfer from 0 to 24 km/h. Electric servo control.



DRIVING SEAT

ROPS-FOPS (UNI 11023) canopy. Reversible seat with automatic inversion of hydraulic steering circuit.



HYDRAULIC SYSTEM

3 independent circuits. 2 variable outlet pumps for hydrostatic transmission and drum rotation. 1 pump for services. Inlet and outlet filter. Heat exchanger water/oil-air type.



LOADING SHOVEL SELF ARTICULATED

Effective capacity per load 400 liters, complete with hydraulic opening gate.



CHUTE

Slewing and hydraulically tilting. 2 extra chutes included.



WATER SYSTEM

Self-contained. Hydraulic driven water pump, water meter, washing outlet.



GRADIENT

Fully loaded 30%.



BRAKES

Oil bath disc brakes inside differential axles. Twin independent circuits. Negative hydraulic parking brake.



TYRES

Off road industrial type 12.5-20 PR 12.



STEERING

Hydrostatic "3-way steering". Radius: internal mm. 1500, external mm. 3400.



ELECTRIC SYSTEM

12 Volt. 120 Ah battery for electric starter and road lighting. Safety battery cut-off.



TANKS

Water: 2 x 275 liters. Diesel: 100 liters. Hydraulic oil: 70 liters.



CHASSIS

Steel profile specially engineered for off-road operations.



WEIGHT

In running order Kg. 5300 equally distributed on both axles.



SAFETY

Machine equipped with checking and block valves for maximum safety of the operator.



CATALOGUE

The machine is equipped with Use and Maintenance and Spare Parts Manuals according to CE regulations.

CARMIX
EVERYWHERE
YOU BUILD